

MICRA-E

DESCRIPTION

- The MICRA-E model is an instrument that admits AC and DC voltage signals up to 600V or current signals up to 5A directly or up to 9999 through an external shunt
- **Eco Function:** Energy saving up to 45 %
- Easily scalable in required engineering unit.
- Programmable by keyboard or via teach method.
- Colour display programmable, Micra-E let you choose between green, amber or red colour assignable to measure, programming or alarm activation.
- Dynamic change of the display color (red-amber-green) for example when reaching a pre-selected value
- 3 Inputs with 16 logic functions programmable.
- 2 Brightness levels for display.
- Total or partial configuration lockout.
- Peak and valley memory.
- Power supply: 85-265 Vac MICRA-E or 10,5-70 Vdc MICRA-E6.
- Communications protocols ASCII, ISO1745, MODBUS-RTU.
- Totally configurable from PC (free software).
- Programmable filter (10 levels)
- Internal resolution A/D ± 15 bits, Sigma-Delta type.



STRUCTURE

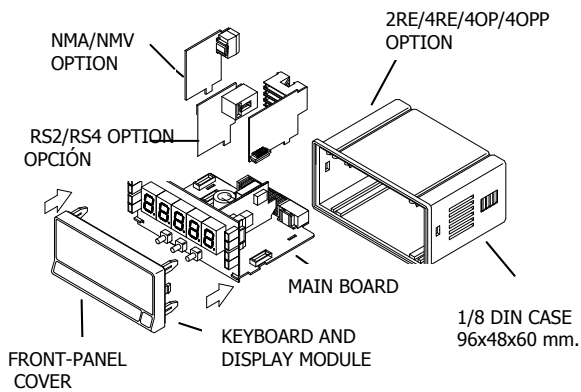

DIMENSIONS AND MOUNTING

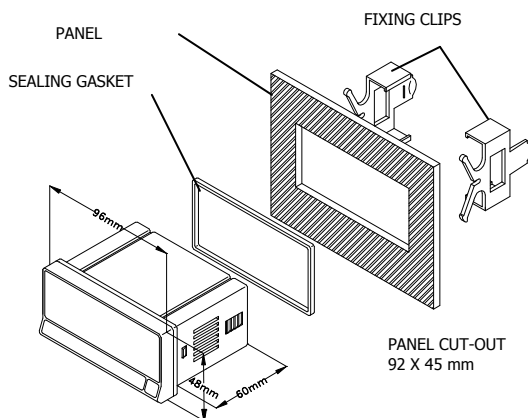

CONNECTIONS

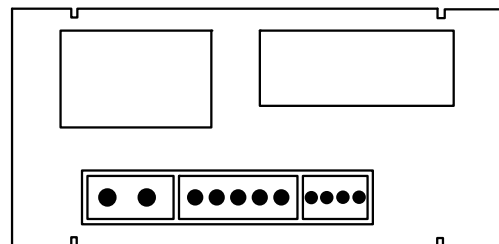

CN1	POWER SUPPLY	
PIN	AC VERSION	DC VERSION
1	AC	VDC
2	AC	VDC
CN2	INPUT SIGNAL	
1	COMMON	
2	SHUNT/ 2V	
3	200 mA	
4	1/ 5 A	
5	20/ 200/ 600 V	
CN3	LOGICAL INPUT	
1	COMMON	
2	INPUT 1	
3	INPUT 2	
4	INPUT 3	

MICRA-E

OPTIONS

The MICRA-E models can accept up to 3 simultaneous options; output option 2RE, 4RE, 4OPP or 4OP; communication option RS2 or RS4 and analogical option NMV or NMA:

- 2 SPDT Relays rating 8 A @ 250 V AC / 150 V DC
Ref.....**2RE**
 - 4 SPST Relays rating 5 A @ 277 V AC / 125 V DC
Ref.....**4RE**
 - 4 NPN Outputs rating 50 mA @ max. 50 V DC
Ref.....**4OP**
 - 4 PNP Outputs rating 50 mA @ max. 50 V DC
Ref.....**4OPP**
- The setpoints are independently programmable for HI / LOW action and time delay or hysteresis operation.*
- RS232C communication output, 1200 to 19200 baud
Ref.....**RS2**
 - RS485 communication output, 1200 to 19200 baud
Ref.....**RS4**
- Serial communication protocols: standard, ISO1745 and MODBUS RTU.
- Isolated analogue output 4-20 mA
Ref.....**NMA**
 - Isolated analogue output 0-10 V
Ref.....**NMV**

STANDARD FUNCTIONS

• PEAK and VALLEY

The instrument detects and memorizes the max and min values reached for the variable after the last reset (peak and valley).

To display the peak value, press the MAX/MIN key. The second push makes the display calls up the valley value (Also at connector CN3).

• RESET PEAK AND VALLEY MEMORY

The peak and valley memories can be reset back to their default values by pressing the MAX/MIN key for 3 seconds, taking into account that the reset value of these memories is the current value of the display when the reset is carried out. The same function is available at the CN3 connector.

• HOLD

The hold function is only accessible from the CN3 connector. The hold condition (display frozen) is maintained as long as the corresponding logic input is kept at "0" level.

FRONT-PANEL FUNCTIONS

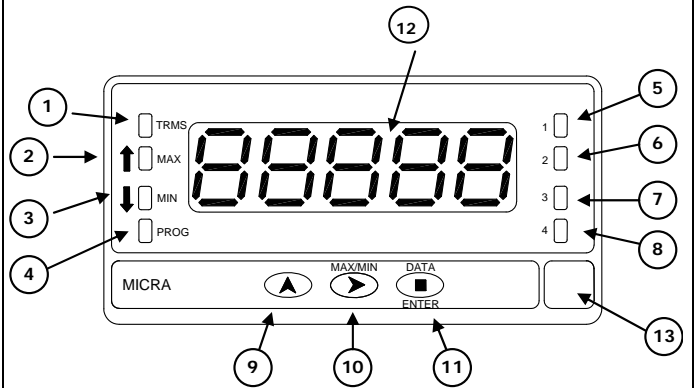

MODE		RUN	PROG
TRMS	1	AC measurement indication	-
MAX	2	Display shows peak value	-
MIN	3	Display shows valley value	-
PROG	4	-	PROG mode activated
DISPLAY	12	Measured value displayed	Displays programming parameters
Key ▲	9		Increments the value of the flashing digit
MAX/MIN key	10	Recalls peak/valley values	Moves to the right
Tecla ENTER	11	Enters in PROG mode. Displays data	Accepts data. Advances program
Etiqueta	13	Engineering unit	
LED 1	5	Output 4 activated	Programming output 4
LED 3	6	Output 3 activated	Programming output 3
LED 2	7	Output 2 activated	Programming output 2
LED 1	8	Output 1 activated	Programming output 1

Logic Programmable Functions CN3

The rear connector CN3 provides 3 user programmable optocoupled inputs that can be operated from external contacts or logic levels supplied by an electronic system.

Three different functions may be then added to the functions available from the front-panel keys. Each function is associated to one of the CN3 connector pins (PIN 2, PIN 3 and PIN 4) and is activated by applying a falling edge or a low level pulse to the corresponding pin with respect to common (PIN 1). Each pin can be assigned one of the 16 functions listed on the following pages.

(*) Factory configuration.

N°	Function	Description	Activation
0	Deactivated	None	None
1	Deactivated	None	None
2	Deactivated	None	None
3	PEAK	Displays the peak value. (MAX.) one pulse brings back to normal reading	Low level
4	VALLEY	Displays the valley value. (MIN) one pulse brings back to normal reading	Low level
5	RESET PEAK/VALLEY	Perform a reset of the peak or the valley, depending on which is being displayed.	Falling edge
6	HOLD	Freeze the display while all the outputs remain active	Low level
7	PRINT	Sends the display value to the printer	Falling edge
8	Deactivated	None	None
9	Deactivated	None	None
10	ASCII	Sends the last four digits to a MICRA-S.	Falling edge
11	BRIGHTNESS	Change the display brightness from Hi to Low	Low level
12	SETPOINT VALUE	Displays the selected setpoint value (see diagram next page)	Low level
13	False Setpoints	Simulates that the instrument has a four setpoints option installed (4RE)	Low level
14	PRINT MAX	Sends the MAX value to the printer	Falling edge
15	PRINT MIN	Sends the MIN value to the printer	Falling edge
16	Remote keypad	The three logic inputs act as a remote keypad	Edge

MICRA-E

SPECIAL FUNCTIONS

- Return to the factory configuration.
- Programmable color change display
- Total or partial lockout of the configuration by code.

ACCURACY

- Temperature coefficient.....100ppm/°C
- Warm-up time15 minutes

FUSES (DIN 41661) Recommended (not incl.)

- MICRA-EF 0.2A/ 250V
- MICRA-E6F 2A/ 250V

POWER SUPPLY

- UNIVERSAL.....85 – 265 Vac
100 – 300Vdc
- LOW VOLTAGE.....10,5 – 70 Vdc
22 – 53 Vac
- Consumption 5 W without options, 8 W max.

A/D CONVERSION

- Technique Sigma-Delta
- Resolution ±15 bits
- Rate20/s

FILTERS

Filter P (1 to 9)

- Cut-off frequency..... from 4 Hz to 0.05 Hz
- Slope 20 dB/decade

DISPLAY

- Range -19999/ 19999
- Digits...5 LED of 14mm Programmable colour (Red, Green, Amber)
- LEDs 8, functions and outputs status
- Display refresh rate.....20/ s
- Overflow indication *-oUEr, oUEr*

ENVIRONMENTAL

- Operating temperature.....-10 °C to +60 °C
- Storage temperature -25 °C to 80 °C
- Relative humidity <95% to 40 °C
- Max. Altitude2000 m

MECHANICAL

- Dimensions.....1/8 DIN case, 96x48x60 mm
- Weight 135g
- Case material.....UL 94 V-0 polycarbonate
- Sealed front panel..... IP65 (indoor use)

ORDERING REFERENCES

- 85-265 V AC 50/60 Hz and 100-300 V DC. MICRA-E
- 21-53 V AC 50/60 Hz and 10,5-70 V DC ..MICRA-E6

INPUT SIGNAL

Volts DC

Range	Accuracy (*)	Input impedance	Resolution
2 V	0.05% L ± 0.3 mV	100 kΩ	0.1 mV
20 V	0.05% L ± 3 mV	1 MΩ	1 mV
200 V	0.05% L ± 30 mV.	1 MΩ	10 mV
600 V	0.05% L ± 0.3 V	1 MΩ	0.1 V

Volt AC

Range	Accuracy (*)	Input impedance @ 50 Hz	Resolution
2 V	0.3% L ± 0.3 mV	75 kΩ	0.1 mV
20 V	0.3% L ± 3 mV	850 kΩ	1 mV
200 V	0.3% L ± 30 mV	850 kΩ	10 mV
600 V	0.3% L ± 0.3 V	850 kΩ	0.1 V

Current DC

Range	Accuracy (*)	Input impedance	Resolution
200 mA	0.1 % L ± 0.05 mA	0.75 Ω	0.01 mA
1 A	0.1 % L ± 5 mA	0.014 Ω	1 mA
5 A	0.1 % L ± 5 mA	0.014 Ω	1 mA
50 mV	0.1 % L ± 0.1 mV	1.8 MΩ	0.01 mV
60 mV	0.1 % L ± 0.1 mV	1.8 MΩ	0.01 mV
100 mV	0.1 % L ± 0.1 mV	1.8 MΩ	0.01 mV

Current AC

Range	Accuracy (*)	Input impedance @ 50 Hz	Resolution
200 mA	0.3 % L ± 0.05 mA	0.75 Ω	0.01 mA
1 A	0.3 % L ± 5 mA	0.014 Ω	1 mA
5 A	0.3 % L ± 5 mA	0.014 Ω	1 mA
50 mV	0.3 % L ± 0.1 mV	1.5 MΩ	0.01 mV
60 mV	0.3 % L ± 0.1 mV	1.5 MΩ	0.01 mV
100 mV	0.3 % L ± 0.1 mV	1.5 MΩ	0.01 mV

(*)

- 15 minutes warmup.
- Accuracy at 25 °C ±5 °C
- 10- 75 % R.H non condensing.

(**)

- 15 minutes warmup.
- Accuracy at 25 °C ±5 °C
- 10- 75 % R.H non condensing.
- 45 Hz -400 Hz sine wave input.
- 3% to 100 % of range.
- Crest Factor: 3 ±(0.2% +10 Digits)
- Crest Factor: 5 ±(1% + 20 Digits)
- 40 HZ-10 kHz range: ±(1% +20 Digits)